

MACOM KV CAPS[™]

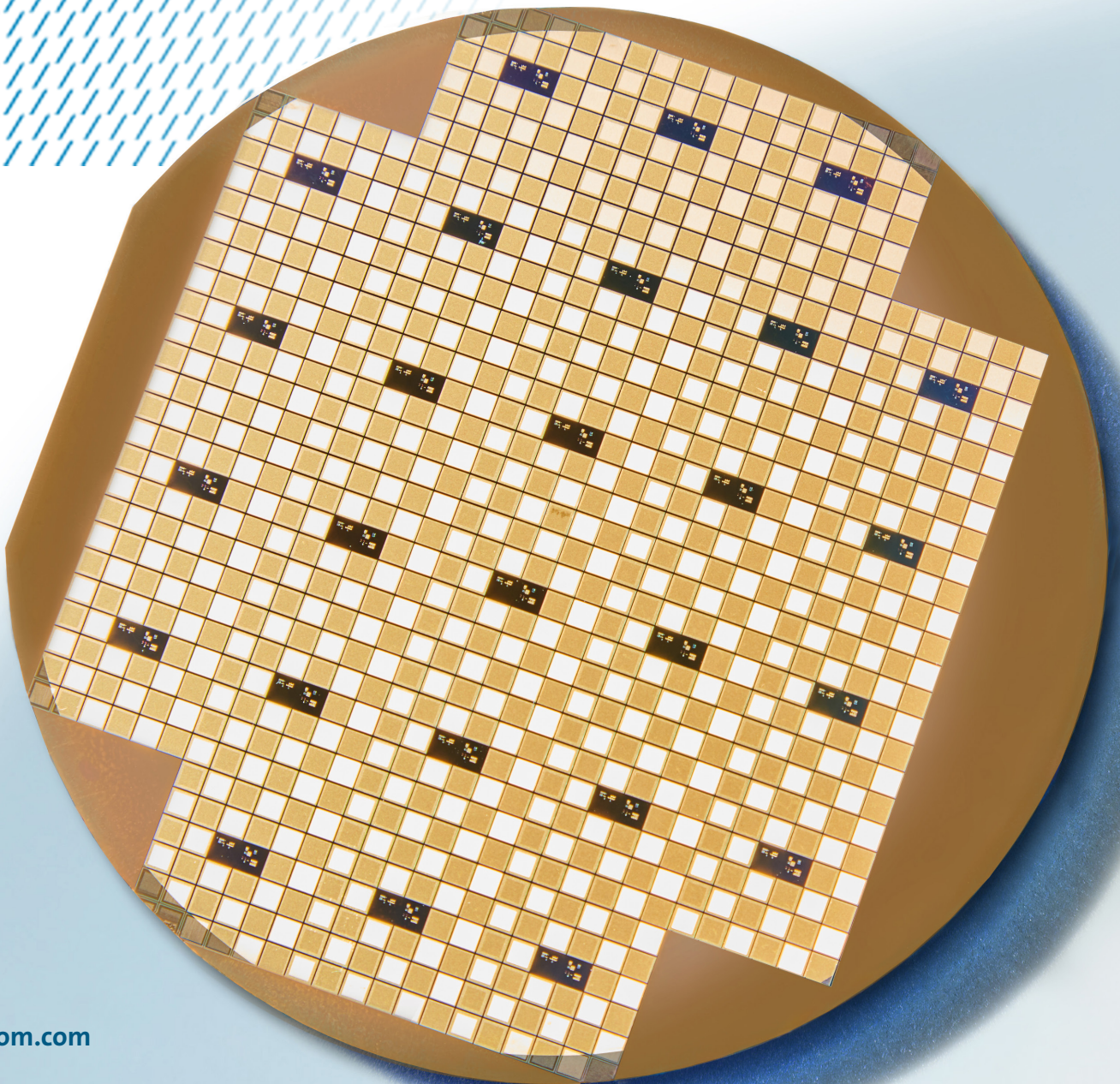

MACOM KV CAPS™ silicon high voltage capacitors are high-density, high-working voltage silicon capacitors which employ a novel topology that essentially folds the parallel plates of the capacitors into three-dimensional structures, producing greater capacitance per unit area of die footprint than that of a simple parallel plate capacitor. This technology employs high reliability materials and wafer processing which have been staples of the semiconductor industry for decades.

Contents

Overview 3-4

- > Target Markets
- > Capacitance vs Size

Description of Product Families 5

200 V Product Family 6-7

- > Capacitance Range
- > Typical Performance Plots
- > Absolute Maximum Ratings
- > Aging
- > Reliability
- > Packaging
- > Tables

500 V Product Family 8-9

- > Capacitance Range
- > Typical Performance Plots
- > Absolute Maximum Ratings
- > Aging
- > Reliability
- > Packaging
- > Tables

1000 V Product Family 10-12

- > Capacitance Range
- > Typical Performance Plots
- > Absolute Maximum Ratings
- > Aging
- > Reliability
- > Packaging
- > Tables

Performance Advantages 12-17

Contact Information 18

Industry's Highest Voltage Semiconductor-Based Capacitors

Overview

MACOM KV CAPS™

High Voltage Capacitors for Demanding Applications

MACOM KV CAPS™ are high-density, high working voltage silicon capacitors which employ a novel topology that essentially folds the parallel plates of the capacitors into three-dimensional structures, producing greater capacitance per unit area of die footprint than that of a simple parallel plate capacitor. This technology employs high reliability materials and wafer processing which have been staples of the semiconductor industry for decades.

MACOM's KV CAPS™ have the highest available working voltage ratings for silicon-based capacitors. These products are offered with 200V or 500V working voltage ratings and are ideal for use in demanding chip-and-wire circuits for DC blocking, AC bypass, and resonant-circuit applications.

These capacitors feature very small change in capacitance versus temperature, typically varying less than $\pm 0.5\%$ over the temperature range of -55 to +300 °C. Their capacitance is not affected by bias voltage and their long-term capacitance stability is excellent, as is their reliability.

MACOM KV CAPS™ have very low equivalent series resistance and equivalent series inductance.



Target Markets

MACOM KV CAPS™ chip capacitors are ideally suited for use in demanding, high-reliability market applications as found in:

- > Aerospace and defense
- > Industrial
- > Test and measurement
- > Medical
- > Automotive
- > and more

MACOM KV CAPS™ chip capacitors are capable of meeting the requirements of:

- > MIL-PRF-35834
- > MIL-STD-883
- > MIL-PRF-19500
- > MIL-STD-750
- > and more

All KV CAPS™ are fully compliant with RoHS requirements.

MACOM KV CAPS™

Greater Capacitance per Footprint Area

MACOM KV CAPS™ employ a novel geometry variation of the single-layer, parallel-plate capacitor geometry to produce greater capacitance per footprint area than a planar parallel plate capacitor.

KV CAPS™ utilize trenches in the top surface of the silicon die. The silicon substrate has very low resistivity and is utilized as the bottom plate of the structure. Thin film dielectric material is deposited on the entire top surface of the substrate to form the middle, insulating layer of the capacitor. The top surface of the dielectric layer is coated with a conductive material to form the top plate of the capacitor structure. This geometry effectively increases the common area of the parallel plates since the areas of the bottoms, tops and side walls of the trenches all comprise the effective area of the parallel plate capacitor structure.

The 200 V and 500 V families of capacitors are available as unpackaged chips, optimized for chip-and-wire hybrid circuit applications. The outermost layers of the topside and backside contacts are gold.

The 1000 V family of capacitors are available in surface mount plastic packages.

Capacitance vs Size

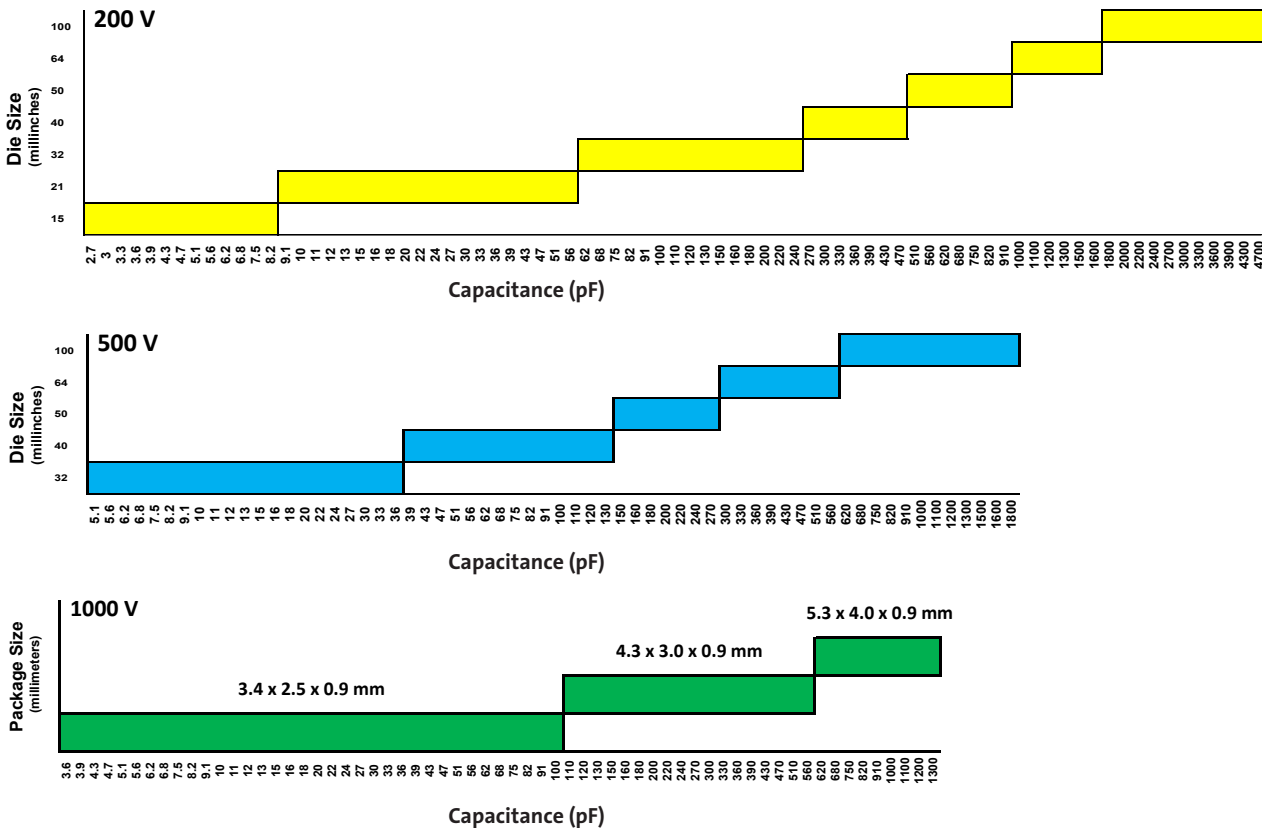

MACOM KV CAPS™

Product Families

MACOM has developed novel, proprietary wafer structures and features to enhance the working voltage of these structures to levels unequalled for semi-conductor-based capacitors.

KV CAPS™ are offered in families, classified by DC working voltage (DCWV):

- > DCWV = 200 V – Capacitance Values from 2.7 pF to 4.7 nF
- > DCWV = 500 V – Capacitance Values from 5.1 pF to 1.8 nF
- > Operating Temperature Range -55 to 300 °C
- > DCWV = 1000 V – Capacitance Values from 3.6 pF to 1.3 nF

High Reliability Applications

MACOM KV CAPS™ capacitors are available for high reliability applications. These devices are capable of meeting the requirements of MIL-PRF-35834 Class K for use in chip-and-wire hybrid circuits.

These capacitors are also available in several types of hermetically sealed ceramic packages.

The suitable package style for a KV CAPS™ capacitor is primarily determined by the size of the capacitor die as well as the voltage rating of the die. Consult the factory for details.

Suggested Hermetic Packages for KV CAPS™ Capacitors

Package Style	Compatible Die Outlines
ODS-30	ODS-1438, ODS-1439, ODS-1440, ODS-1441
ODS-186	ODS-1438, ODS-1439, ODS-1440, ODS-1441
ODS-1027	ODS-1445, ODS-1446, ODS-1442, ODS-1443, ODS-1444, ODS-1447, ODS-1448, ODS-1449



Reliability

The dielectric materials and their properties have been carefully selected to provide excellent reliability. FIT rate less than 1 FIT for 1 million hours operation with applied voltage of 120% of rated working voltage.

Capacitance Range: 2.7 pF to 4.7 nF

Parameter	Conditions	Minimum	Typical	Maximum	Units
Temperature Coefficient of Capacitance			< 27		ppm/°C
Capacitance Tolerance	WRT Nominal Value	-5		+5	%
Insulation Resistance	T _A = 25 °C at 80% of Rated Working Voltage		≥ 10		GΩ
Equivalent Series Inductance (ESL)	for Bare Die		≤ 0.5		nH
Equivalent Series Resistance (ESR)			≤ 100		mΩ

Typical Performance Plots

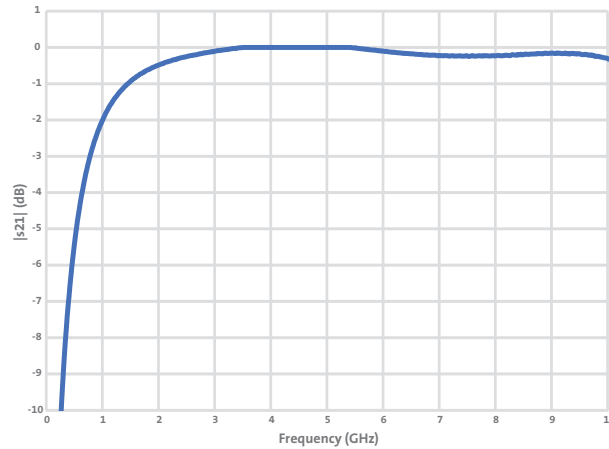

Data for a 2.7 pF Capacitor – Series Connected

Absolute Maximum Ratings T = 25 °C (unless otherwise noted)

Parameter	Value	Units
Operating Temperature Range	-55 to 250	°C
Storage Temperature Range	-70 to 300	°C
Applied DC Voltage	200	V

Aging/Reliability

Capacitance does not change vs. time

Electrostatic Discharge

Class 1B (HBM)

Reliability

FIT rate less than 1 FIT for 1 million hours operation

Finishing

Top and bottom contacts Au, compatible with wire bonding, eutectic and RoHS solders

Packaging for Shipment

- > Gel paks
- > Separate section

Product Storage Recommendations and Shelf Life Information

- > Protect from moisture & high humidity
- > Au metalization provides indefinite shelf life

200 V						
Part Number	Capacitance Tolerance (%)	Voltage (V)	Die Size (mils ²)	Value (pF)	Package Type	Package
MKVC-2A02R7	+/-5	200	15	2.7	Waffle & Gel	ODS-1438
MKVC-2A03R0	+/-5	200	15	3	Waffle & Gel	ODS-1438
MKVC-2A03R3	+/-5	200	15	3.3	Waffle & Gel	ODS-1438
MKVC-2A03R9	+/-5	200	15	3.9	Waffle & Gel	ODS-1438
MKVC-2A04R7	+/-5	200	15	4.7	Waffle & Gel	ODS-1438
MKVC-2A06R8	+/-5	200	15	6.8	Waffle & Gel	ODS-1438
MKVC-2A08R2	+/-5	200	15	8.2	Waffle & Gel	ODS-1438
MKVC-2A10R0	+/-5	200	21	10	Waffle & Gel	ODS-1439
MKVC-2A16R0	+/-5	200	21	16	Waffle & Gel	ODS-1439
MKVC-2A20R0	+/-5	200	21	20	Waffle & Gel	ODS-1439
MKVC-2A33R0	+/-5	200	21	33	Waffle & Gel	ODS-1439
MKVC-2A39R0	+/-5	200	21	39	Waffle & Gel	ODS-1439
MKVC-2A47R0	+/-5	200	21	47	Waffle & Gel	ODS-1439
MKVC-2A68R0	+/-5	200	32	68	Waffle & Gel	ODS-1440
MKVC-2A82R0	+/-5	200	32	82	Waffle & Gel	ODS-1440
MKVC-2A91R0	+/-5	200	32	91	Waffle & Gel	ODS-1440
MKVC-2A0100	+/-5	200	32	100	Waffle & Gel	ODS-1440
MKVC-2A0110	+/-5	200	32	110	Waffle & Gel	ODS-1440
MKVC-2A0120	+/-5	200	32	120	Waffle & Gel	ODS-1440
MKVC-2A0130	+/-5	200	32	130	Waffle & Gel	ODS-1440
MKVC-2A0150	+/-5	200	32	150	Waffle & Gel	ODS-1440
MKVC-2A0160	+/-5	200	32	160	Waffle & Gel	ODS-1440
MKVC-2A0180	+/-5	200	32	180	Waffle & Gel	ODS-1440
MKVC-2A0200	+/-5	200	32	200	Waffle & Gel	ODS-1440
MKVC-2A0200	+/-5	200	32	220	Waffle & Gel	ODS-1440
MKVC-2A0240	+/-5	200	32	240	Waffle & Gel	ODS-1440
MKVC-2A0270	+/-5	200	40	270	Waffle & Gel	ODS-1441
MKVC-2A0300	+/-5	200	40	300	Waffle & Gel	ODS-1441
MKVC-2A0330	+/-5	200	40	330	Waffle & Gel	ODS-1441
MKVC-2A0360	+/-5	200	40	360	Waffle & Gel	ODS-1441
MKVC-2A3900	+/-5	200	40	390	Waffle & Gel	ODS-1441
MKVC-2A0680	+/-5	200	50	680	Waffle & Gel	ODS-1442
MKVC-2A0820	+/-5	200	50	820	Waffle & Gel	ODS-1442
MKVC-2A1000	+/-5	200	64	1000	Waffle & Gel	ODS-1443
MKVC-2A1600	+/-5	200	64	1600	Waffle & Gel	ODS-1443
MKVC-2A2200	+/-5	200	100	2200	Waffle & Gel	ODS-1444
MKVC-2A2700	+/-5	200	100	2700	Waffle & Gel	ODS-1444
MKVC-2A3300	+/-5	200	100	3300	Waffle & Gel	ODS-1444

Contact your sales rep to learn about more products available in this family

Note: Part numbers are RoHS compliant
 Detailed specifications can be found quickly on our website at macom.com by typing the part number into the search box.
 All specifications are subject to change.

Capacitance Range: 5.1 pF to 1.8 nF

Parameter	Conditions	Minimum	Typical	Maximum	Units
Temperature Coefficient of Capacitance	$-55\text{ }^{\circ}\text{C} \leq T_A \leq 250\text{ }^{\circ}\text{C}$			50	ppm/ $^{\circ}\text{C}$
Capacitance Tolerance	WRT Nominal Value	-5		+5	%
Insulation Resistance	$T_A = 25\text{ }^{\circ}\text{C}$ at 80% of Rated Working Voltage	10			$\text{G}\Omega$
Equivalent Series Inductance (ESL)	for Bare Die				nH
Equivalent Series Resistance (ESR)					m Ω

Typical Performance Plots

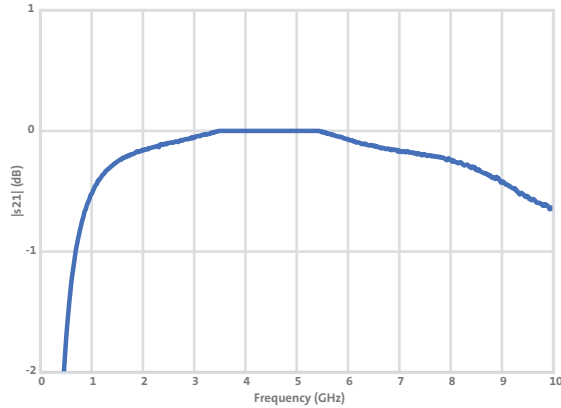

Data for a 5.1 pF capacitor – series connected

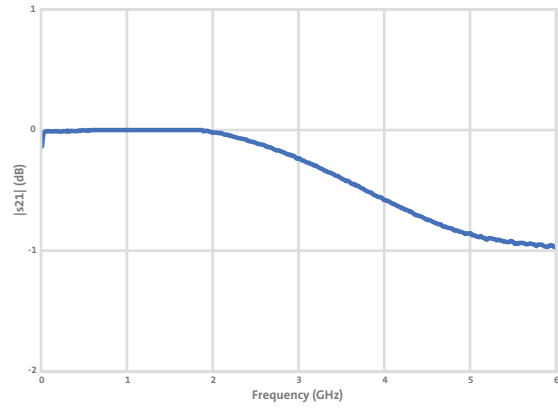

Data for a 1.1 nF capacitor – series connected

Absolute Maximum Ratings $T = 25\text{ }^{\circ}\text{C}$ (unless otherwise noted)

Parameter	Value	Units
Operating Temperature Range	-55 to 250	$^{\circ}\text{C}$
Storage Temperature Range	-70 to 300	$^{\circ}\text{C}$
Applied DC Voltage	500	V

Aging/Reliability

Capacitance does not change vs. time

Electrostatic Discharge

Class 1C (HBM)

Reliability

FIT rate less than 1 FIT for 1 million hours operation

Finishing

Top and bottom contacts Au, compatible with wire bonding, eutectic and RoHS solders

Packaging for Shipment

- > Gel paks
- > Separate section

Product Storage Recommendations and Shelf Life Information

- > Protect from moisture & high humidity
- > Au metalization provides indefinite shelf life

500 V						
Part Number	Capacitance Tolerance (%)	Voltage (V)	Die Size (mils ²)	Value (pF)	Package Type	Package
MKVC-5A05R1	+/-5	500	32	5.1	Waffle & Gel	ODS-1445
MKVC-5A05R6	+/-5	500	32	5.6	Waffle & Gel	ODS-1445
MKVC-5A06R2	+/-5	500	32	6.2	Waffle & Gel	ODS-1445
MKVC-5A06R8	+/-5	500	32	6.8	Waffle & Gel	ODS-1445
MKVC-5A07R5	+/-5	500	32	7.5	Waffle & Gel	ODS-1445
MKVC-5A0240	+/-5	500	32	240	Waffle & Gel	ODS-1447
MKVC-5A0270	+/-5	500	32	270	Waffle & Gel	ODS-1447
MKVC-5A0100	+/-5	500	40	100	Waffle & Gel	ODS-1446
MKVC-5A0110	+/-5	500	40	110	Waffle & Gel	ODS-1446
MKVC-5A0120	+/-5	500	40	120	Waffle & Gel	ODS-1446
MKVC-5A0130	+/-5	500	40	130	Waffle & Gel	ODS-1446
MKVC-5A0150	+/-5	500	50	150	Waffle & Gel	ODS-1447
MKVC-5A0160	+/-5	500	50	160	Waffle & Gel	ODS-1447
MKVC-5A0180	+/-5	500	50	180	Waffle & Gel	ODS-1447
MKVC-5A0200	+/-5	500	50	200	Waffle & Gel	ODS-1447
MKVC-5A0220	+/-5	500	50	220	Waffle & Gel	ODS-1447
MKVC-5A0300	+/-5	500	64	300	Waffle & Gel	ODS-1448
MKVC-5A0330	+/-5	500	64	330	Waffle & Gel	ODS-1448
MKVC-5A0360	+/-5	500	64	360	Waffle & Gel	ODS-1448
MKVC-5A0390	+/-5	500	64	390	Waffle & Gel	ODS-1448
MKVC-5A0430	+/-5	500	64	430	Waffle & Gel	ODS-1448
MKVC-5A0470	+/-5	500	64	470	Waffle & Gel	ODS-1448
MKVC-5A0510	+/-5	500	64	510	Waffle & Gel	ODS-1448
MKVC-5A0560	+/-5	500	64	560	Waffle & Gel	ODS-1448
MKVC-5A0620	+/-5	500	100	620	Waffle & Gel	ODS-1449
MKVC-5A0680	+/-5	500	100	680	Waffle & Gel	ODS-1449
MKVC-5A0750	+/-5	500	100	750	Waffle & Gel	ODS-1449
MKVC-5A1100	+/-5	500	100	1100	Waffle & Gel	ODS-1449
MKVC-5A1200	+/-5	500	100	1200	Waffle & Gel	ODS-1449
MKVC-5A1300	+/-5	500	100	1300	Waffle & Gel	ODS-1449
MKVC-5A1500	+/-5	500	100	1500	Waffle & Gel	ODS-1449
MKVC-5A1600	+/-5	500	100	1600	Waffle & Gel	ODS-1449
MKVC-5A1800	+/-5	500	100	1800	Waffle & Gel	ODS-1449

Contact your sales rep to learn about more products available in this family

Capacitance Range: 5.1 pF to 1.8 nF

Parameter	Conditions	Minimum	Typical	Maximum	Units
Temperature Coefficient of Capacitance	$-55\text{ }^{\circ}\text{C} \leq T_A \leq 250\text{ }^{\circ}\text{C}$			50	ppm/ $^{\circ}\text{C}$
Capacitance Tolerance	WRT Nominal Value	-5		+5	%
Insulation Resistance	$T_A = 25\text{ }^{\circ}\text{C}$ at 80% of Rated Working Voltage	10			G Ω
Equivalent Series Inductance (ESL)			1.5		nH
Equivalent Series Resistance (ESR)			750		m Ω

Typical Performance Plots

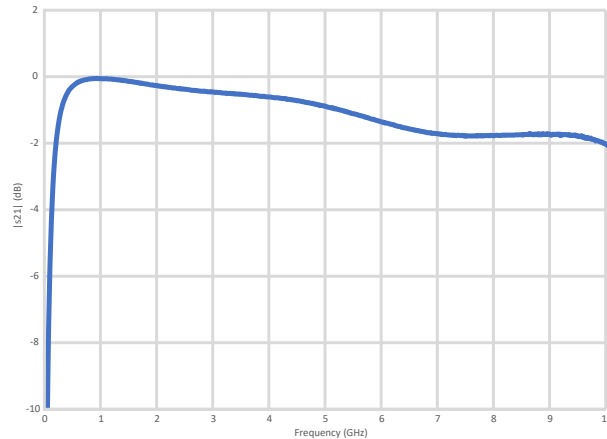

Data for a 10 pF Capacitor – Series Connected

Absolute Maximum Ratings T = 25 °C (unless otherwise noted)

Parameter	Value	Units
Operating Temperature Range	-55 to 250	$^{\circ}\text{C}$
Storage Temperature Range	-70 to 300	$^{\circ}\text{C}$
Applied DC Voltage	1000	V

Aging/Reliability:

Capacitance does not change vs. time

Electrostatic Discharge

Class 2 (HBM)

Reliability:

FIT rate less than 1 FIT for 1 million hours operation

Finishing:

Lead Finish: Sn Plate

Packaging for Shipment:

- > The 1000 V KV CAPS™ capacitors are shipped in tape and reel.
- > The quantity per reel is 1000 pieces.

Product Storage Recommendations and Shelf Life Information:

- > Protect from moisture & high humidity
- > Au metalization provides indefinite shelf life

1000 V					
Part Number	Capacitance Tolerance (%)	Voltage (V)	Package Size (mm)	Value (pF)	Packing
MKVC-1A03R6	+/-5	1000	3.4 x 2.5 x 0.9	3.6	T/R
MKVC-1A03R9	+/-5	1000	3.4 x 2.5 x 0.9	3.9	T/R
MKVC-1A04R7	+/-5	1000	3.4 x 2.5 x 0.9	4.7	T/R
MKVC-1A05R6	+/-5	1000	3.4 x 2.5 x 0.9	5.6	T/R
MKVC-1A06R8	+/-5	1000	3.4 x 2.5 x 0.9	6.8	T/R
MKVC-1A07R5	+/-5	1000	3.4 x 2.5 x 0.9	7.5	T/R
MKVC-1A08R2	+/-5	1000	3.4 x 2.5 x 0.9	8.2	T/R
MKVC-1A10R0	+/-5	1000	3.4 x 2.5 x 0.9	10	T/R
MKVC-1A11R0	+/-5	1000	3.4 x 2.5 x 0.9	11	T/R
MKVC-1A13R0	+/-5	1000	3.4 x 2.5 x 0.9	13	T/R
MKVC-1A15R0	+/-5	1000	3.4 x 2.5 x 0.9	15	T/R
MKVC-1A18R0	+/-5	1000	3.4 x 2.5 x 0.9	18	T/R
MKVC-1A20R0	+/-5	1000	3.4 x 2.5 x 0.9	20	T/R
MKVC-1A24R0	+/-5	1000	3.4 x 2.5 x 0.9	24	T/R
MKVC-1A27R0	+/-5	1000	3.4 x 2.5 x 0.9	27	T/R
MKVC-1A33R0	+/-5	1000	3.4 x 2.5 x 0.9	33	T/R
MKVC-1A36R0	+/-5	1000	3.4 x 2.5 x 0.9	36	T/R
MKVC-1A39R0	+/-5	1000	3.4 x 2.5 x 0.9	39	T/R
MKVC-1A47R0	+/-5	1000	3.4 x 2.5 x 0.9	47	T/R
MKVC-1A51R0	+/-5	1000	3.4 x 2.5 x 0.9	51	T/R
MKVC-1A62R0	+/-5	1000	3.4 x 2.5 x 0.9	62	T/R
MKVC-1A75R0	+/-5	1000	3.4 x 2.5 x 0.9	75	T/R
MKVC-1A0100	+/-5	1000	3.4 x 2.5 x 0.9	100	T/R

Contact your sales rep to learn about more products available in this family

MACOM KV™

Greater Performance Advantages

Description

The novel construction of MACOM KV™ offers many performance advantages. These devices are fundamentally parallel-plate capacitors formed on a highly conductive silicon substrate. They incorporate trenched construction which significantly increases their capacitance per unit footprint area while supporting large working voltages. The materials used to form their dielectric layers produce excellent long-term capacitance stability as well as high quality factor and very small change in capacitance versus temperature. These devices contain no magnetic materials.

MACOM KV™ families of 200 V and 500 V working voltage are available as unpackaged chips suitable for industry-standard chip-and-wire construction.

The back side of the die is metalized in several layers, starting with the ohmic contact which is in contact with the Si substrate of the die upon which a layer of a barrier metal is deposited. A solderable layer of metal is formed on the barrier layer and finally an outermost layer of gold is deposited.

The topside metal that contains the trenches also has a barrier metal that is deposited followed by an outermost layer of gold that is suitable for wire/ribbon bonding.

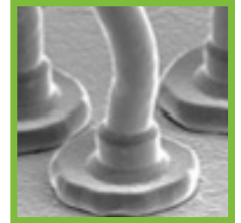

Recommended Package Attach Methods

MACOM recommends that KV Packaged™ may be attached to a circuit substrate using solder or conductive epoxy.

Printed Circuit Board Design

Packaged Capacitors

These devices may be soldered to a PCB using lead (Pb)-bearing or RoHS-compatible solders. The layout of the surface mount board plays a critical role in product design and must be done properly to achieve the intended performance of the device. An accurate PCB pad and solder stencil design provides a proper connection interface between the device package and the board. With the correct pad geometry, the package will self-align when subjected to a solder reflow process and will also allow for just enough excess surface area for adequate solder filleting. The solder mask should be applied over bare copper (SMOBC) to avoid solder reflow under the solder mask. The plating on the PCB could be Electroless Nickel Immersion Gold (ENIG), Electroless Nickel Electroless Palladium Immersion Gold (ENEPIG) or tin plate.

Package Outlines and Land Pads

3.4 x 2.5 x 0.9 mm Package Outline

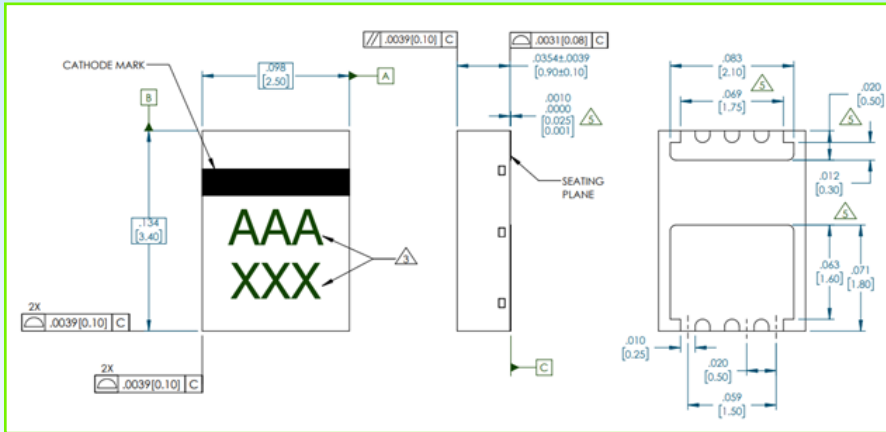

Recommended Land Pad

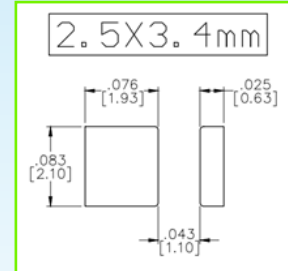

Note: Dimensions in [mm]

Note: Dimensions in [mm]; Lead Finish: Sn Plate

4.3 x 3.0 x 0.9 mm Package Outline

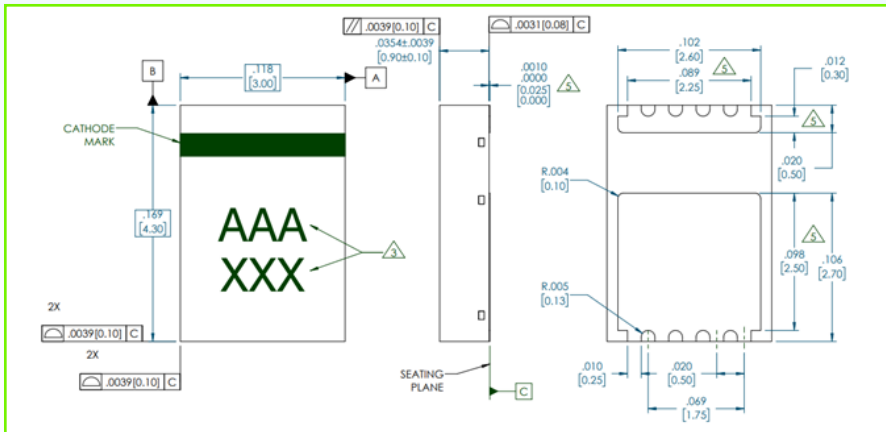

Recommended Land Pad

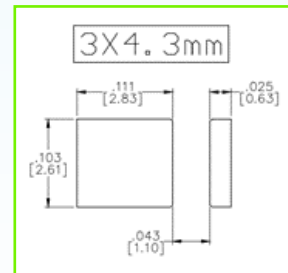

Note: Dimensions in [mm]

Note: Dimensions in [mm]; Lead Finish: Sn Plate

5.3 x 4.0 x 0.9 mm Package Outline

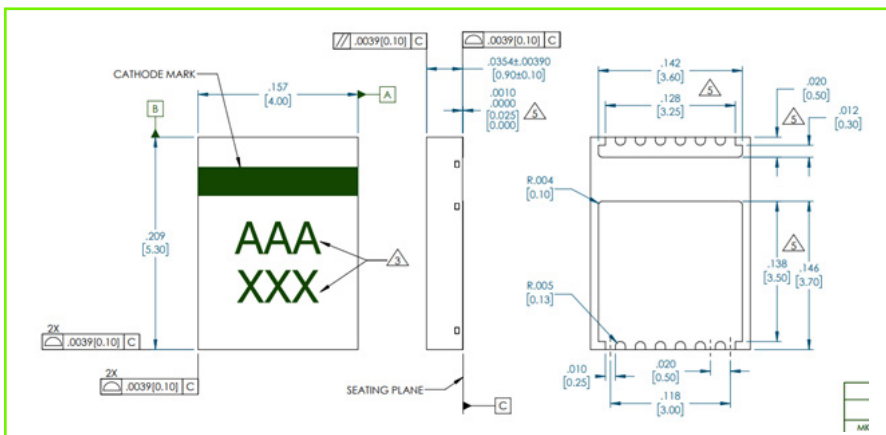

Recommended Land Pad

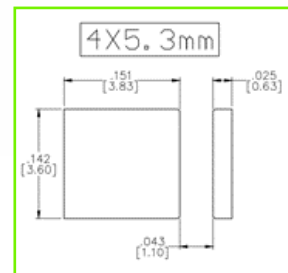

Note: Dimensions in [mm]

Note: Dimensions in [mm]; Lead Finish: Sn Plate

Stencil Design

We recommend a stencil thickness of 0.100 to 0.125 mm. A laser-cut, stainless steel stencil with electro-polished trapezoidal walls is recommended. For consistent release of the solder paste from the stencil a nano coating can be applied to the stencil.

RoHS and Lead Based Reflow Profile Recommendations

The most common solder reflow method for RoHS and lead based solders is accomplished in a belt furnace using convection heat transfer. Table 1 along with Figure 1 show a typical convection reflow profile of temperature versus time. The profile reflects the three distinct heating stages, or zones (preheat, reflow, and cooling) recommended in automated reflow processes to ensure reliable, finished solder joints. The profile will vary among soldering systems and is intended as an example to use as a starting point. Other factors that can affect the profile include the density and types of components on the board, type of solder used and type of board or substrate material being used. Thermocouples should be securely attached to the top surface of a representative component to ensure the temperature exposure is met. Profile should be recorded by data acquisition for future reference.

In these cases, the solder temperature profile recommended by the solder manufacturer should be utilized and shall not exceed the guidelines in the table below, for proper intermetallic formation.

It is important that the following maximum conditions must not be exceeded during the soldering process:

Profile Feature	Sn-Pb Eutectic Assembly	Pb-Free Assembly
Preheat/Soak Temperature Min (T_{Smin})	100 °C	150 °C
Temperature Max (T_{Smax}) Time (t_s) from (T_{Smin} to T_{Smax})	150 °C 60 – 120 seconds	200 °C 60 – 120 seconds
Ramp-Up Rate (T_L to T_P)	3 °C/second max.	3 °C/second max.
Liquidous Temperature (T_L) Time (t_L) Maintained Above T_L	183 °C 60 – 150 seconds	217 °C 60 – 150 seconds
Peak package body temperature (T_P)	For users T_P must not exceed the Classification temperature in Table 4 For suppliers T_P must not exceed the Classification temperature in Table 4	For users T_P must not exceed the Classification temperature in Table 5 For suppliers T_P must not exceed the Classification temperature in Table 5
Time (t_p)* within 5 °C of the specified Classification temperature (T_C), see reflow profile	20 seconds*	30 seconds*
Ramp-Down Rate (T_P) to (T_L)	6 °C/second max.	6 °C/second max
Time 25 °C to Peak Temperature	6 minutes max.	8 minutes max.

* Tolerance for peak profile temperature (T_P) is defined as a supplier minimum and a user maximum

Note 1: All temperatures refer to the center of the package, measured on the package body surface that is facing up during assembly reflow (e.g., live-bug). If parts are reflowed in other than the normal live-bug assembly orientation (i.e., dead-bug), T_p shall be within $\pm 2^\circ\text{C}$ of the live-bug T_p and still meet the T_c requirements, otherwise, the profile shall be adjusted to achieve the latter. To accurately measure actual peak package body temperatures refer the JEP140 for recommended thermocouple use.

Note 2: Reflow profiles in this document are for classification/preconditioning and are not meant to specify board assembly profiles. Actual board assembly profiles should be developed based on specific process needs and board designs and should not exceed the parameters in Table 3. For example, if T_c is 260°C and time t_p is 30 seconds, this means the following for the supplier and the user. For a supplier: The peak temperature must be at least 260°C . The time above 255°C must be at least 30 seconds. For a user: The peak temperature must not exceed 260°C . The time above 255°C must not exceed 30 seconds.

Note 3: All components in the test load shall meet the classification profile requirements.

Note 4: SMD packages classified to a given moisture sensitivity level by using Procedures or Criteria defined within any previous version of J-STD-020, JESD22-A112 (rescinded), IPC-SM-786 (rescinded) do not need to be reclassified to the current revision unless a change in classification level or a higher peak classification temperature is desired.

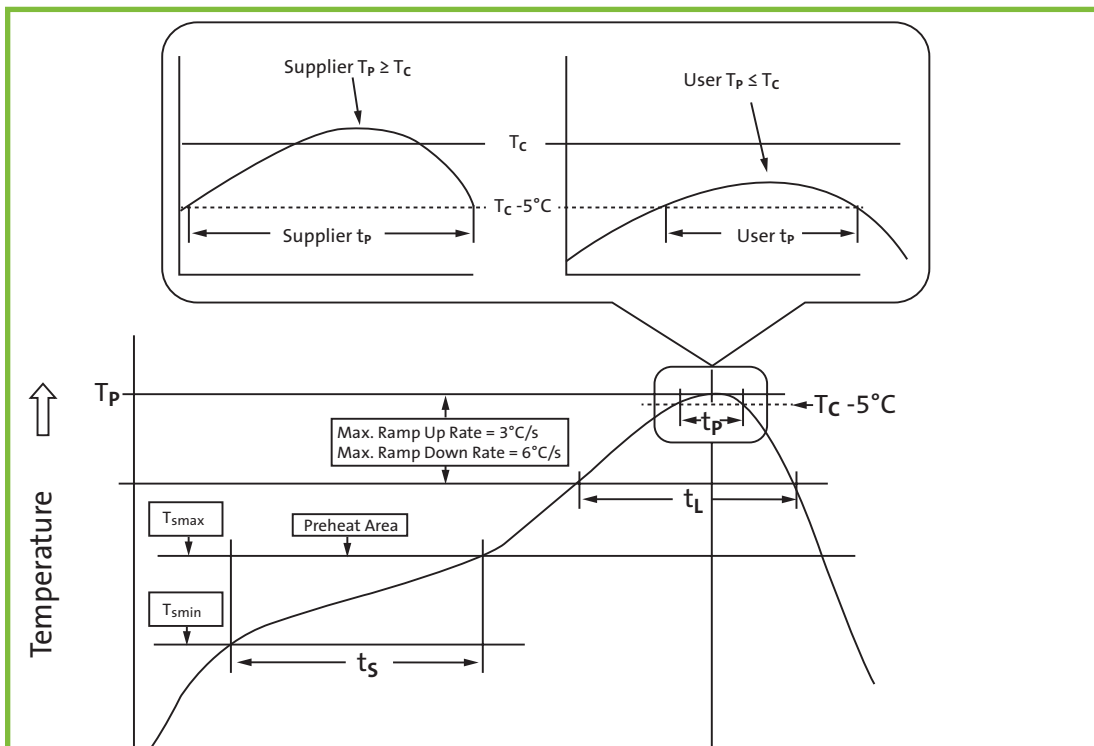

Recommended Die Attach Methods

Unpackaged die may be attached to a circuit medium using solder or conductive epoxy.

Land Pad Design

When designing a pad for conductive epoxy attach it is recommended that the size of the pad be 0.004 inches (0.100 mm) larger than the die on all sides to allow for proper filleting.

For 80/20 AuSn eutectic solder attach a thicker gold plating is recommended for proper intermetallic formation. Typical range is 50 – 100 microinches. When designing the land please refer to the datasheet for the recommended land pad.

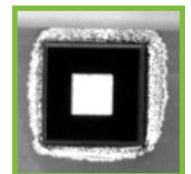

Solder Die Attach

Solder die attach may be accomplished using a eutectic solder, such as Au(80)/Sn(20), leaded solders such as Sn63Pb37 or with any of several RoHS-compatible solders such as Sn96.53Ag0.5Cu (SAC305) etc. For leaded or RoHS solder pastes it is recommended that a no clean solder paste be used to prevent trapped fluxes which cannot be cleaned as recommended by IPC-7093. For lead free and tin lead eutectic solder reflow parameters refer to the table on page 14.

Au(80)/Sn(20) Eutectic Solder Attach

80/20 AuSn solder commonly is supplied as a preform. The recommended preform size is 0.005 inches (0.125 mm) undersized from each edge. Typical preform thickness are 0.001 inches (0.025 mm). MACOM recommends the solder temperature profile shown below for Au(80)/Sn(20) eutectic solder die attach. The solder is typically flowed using heat and forming gas.

It is important that the following maximum conditions must not be exceeded during die attach:

- > maximum solder temperature: 350 °C
- > maximum peak temperature duration: 5 s

Conductive Epoxy Die Attach

MACOM recommends that the surface preparation and curing profiles provided by the manufacturer of the conductive epoxy should be followed. The typical epoxy bond line thickness is 0.0005 to 0.001 inches (12.5 to 25 µm). The curing temperature shall not exceed 350 °C.

Wire/Ribbon Bonding

While the construction of MACOM's KV™ is very robust, it is recommended that wires or ribbons should be attached near to the center of the top contact to prevent mechanical damage, such as micro cracking, to the die which could degrade the working voltage capability of the die. Thermo-compression or ultrasonic bonding can be used. For most capacitance values, the top contact of the KV™ capacitor is sufficiently large to accept the attachment of multiple wires or ribbons. The top contact of the capacitor has a gold plating. Prior to wire or ribbon bonding, plasma cleaning may be required to remove any organic contaminants that could affect the quality of the bond interface. The parameters used can vary, depending on the wire bonding process and wire/ribbon type used. Common alloys which can be used include CuPdAu and Au wires.

MACOM[®]

Partners from RF to Light

Additional product information
can be found on our website at:

macom.com

Contact our worldwide sales
offices, authorized representatives,
and industry-leading distributors
to request samples, test boards,
and application support. All contacts
are listed on our website at:

macom.com/support

MACOM Technology Solutions Inc.

100 Chelmsford Street

Lowell, Massachusetts 01851